

Adapting an **E**xperiment-centric
Teaching **A**pproach to Increase Student
Achievement in Multiple **STEM**
Disciplines (**ETA-STEM**)

November 15, 2019

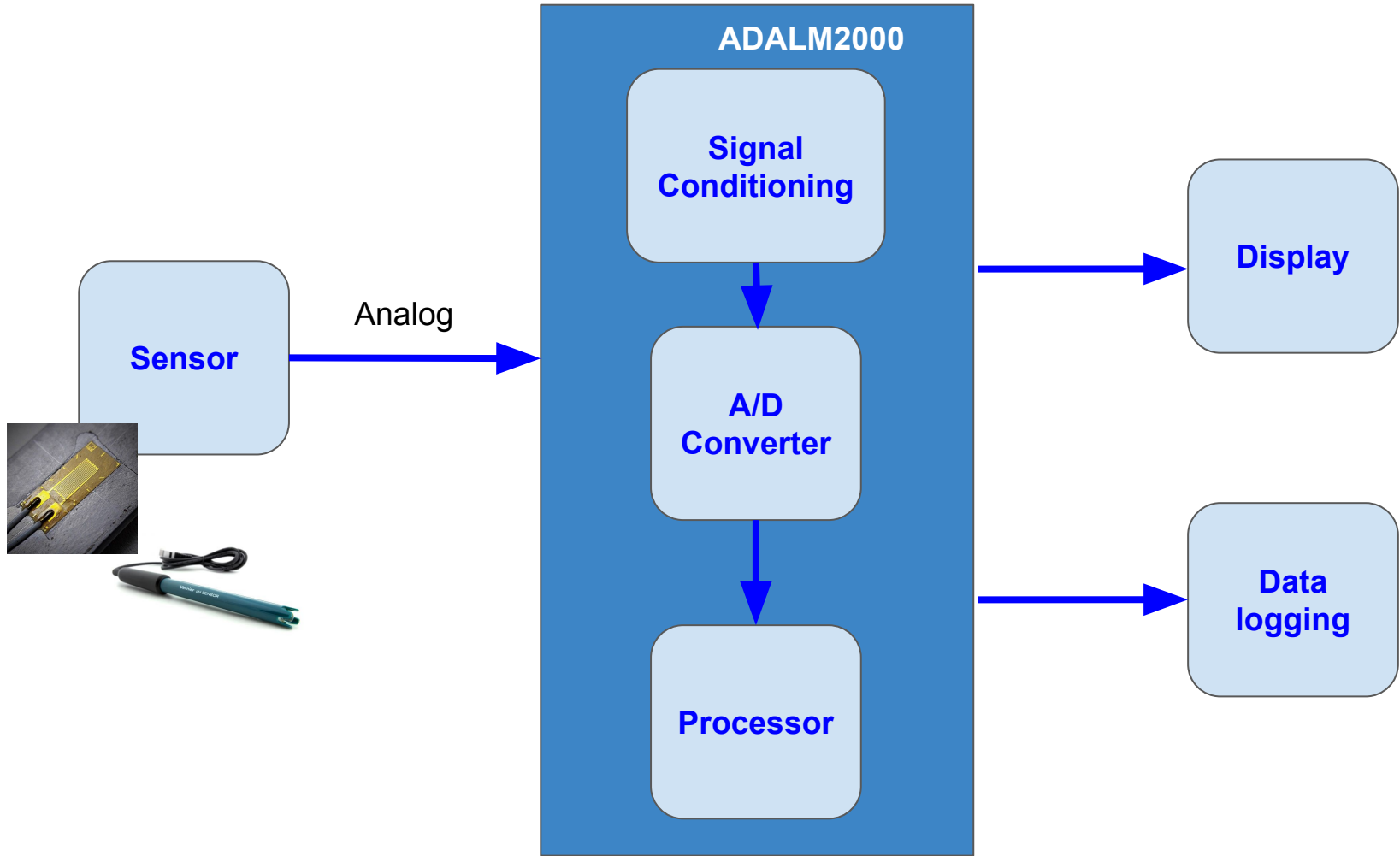

ADALM 2000

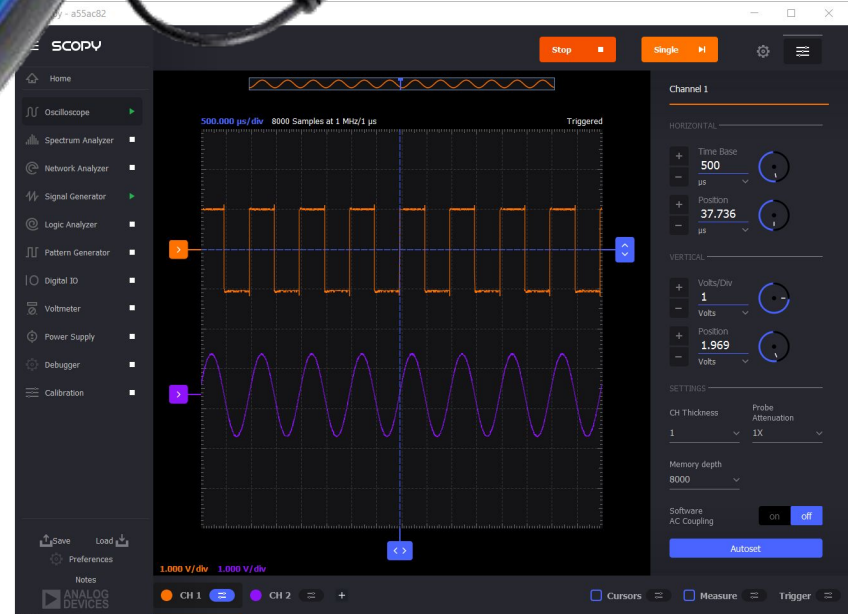
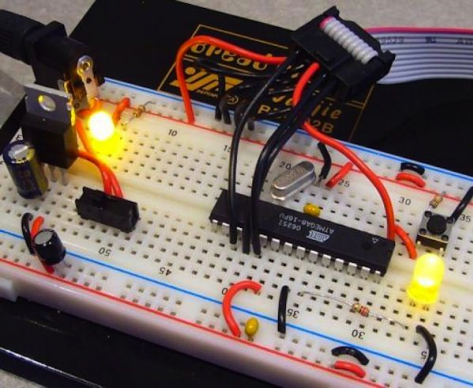

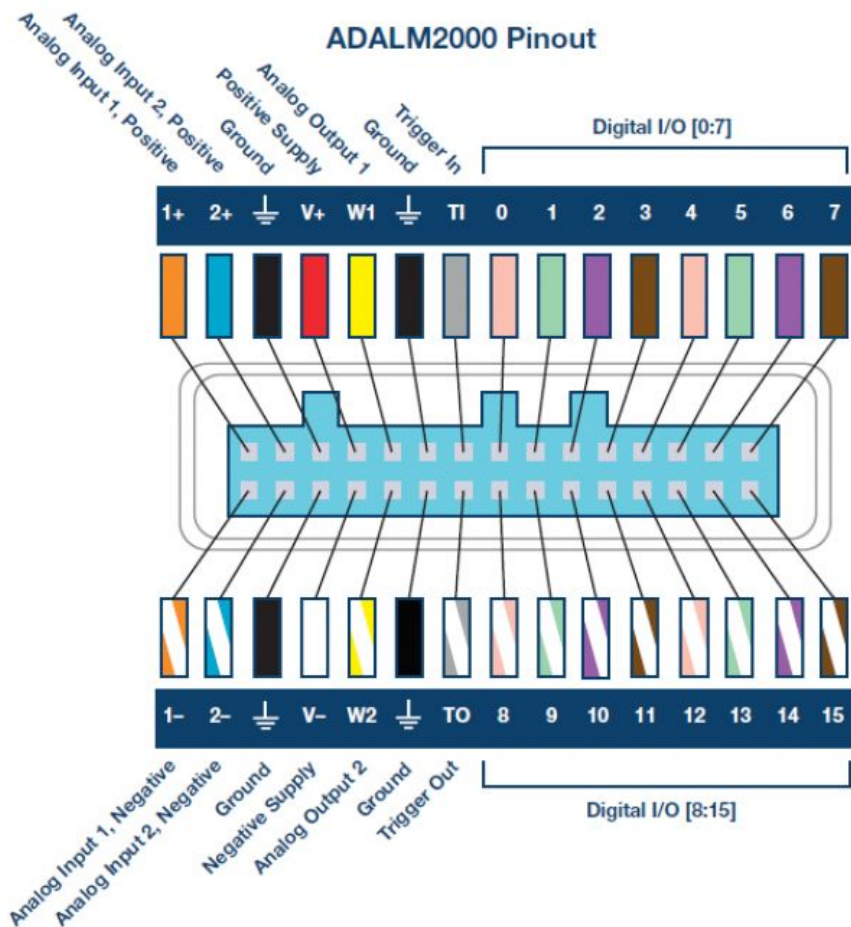
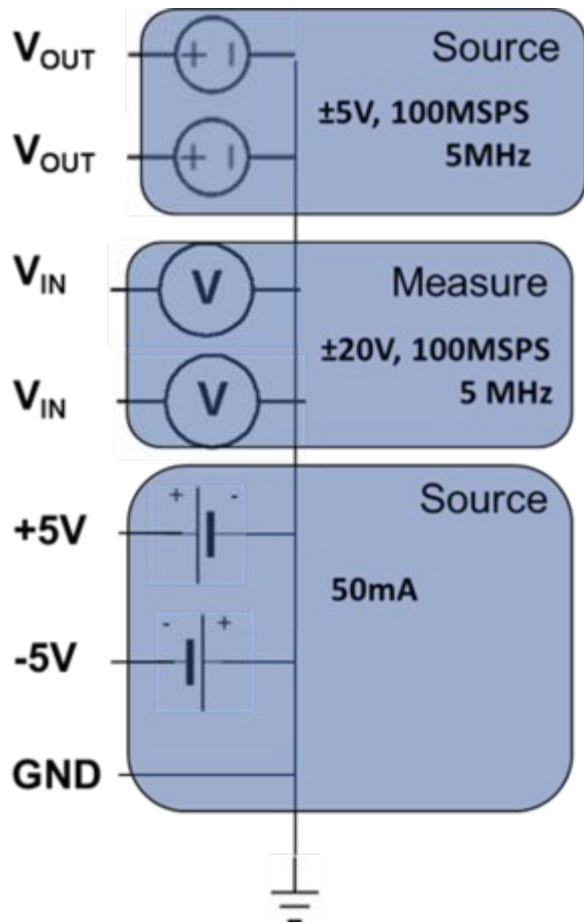

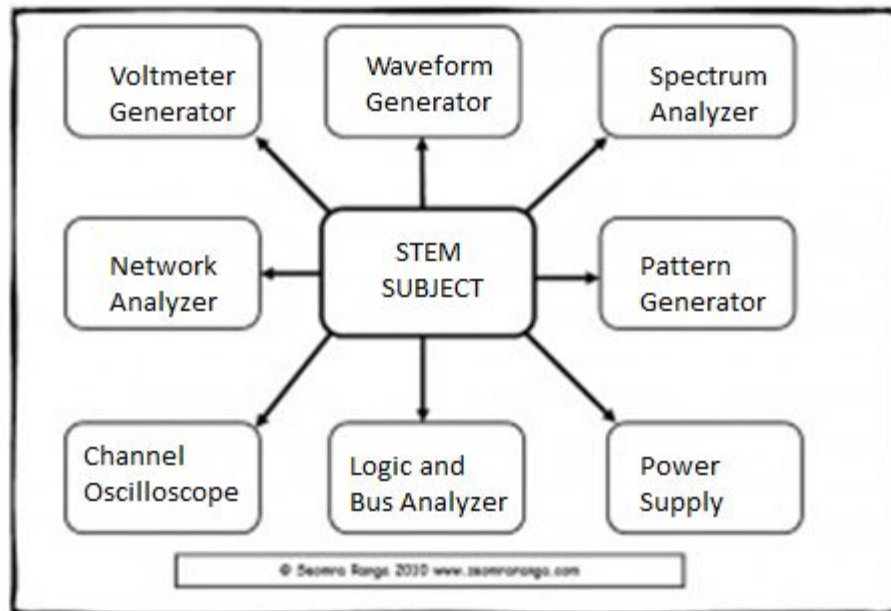

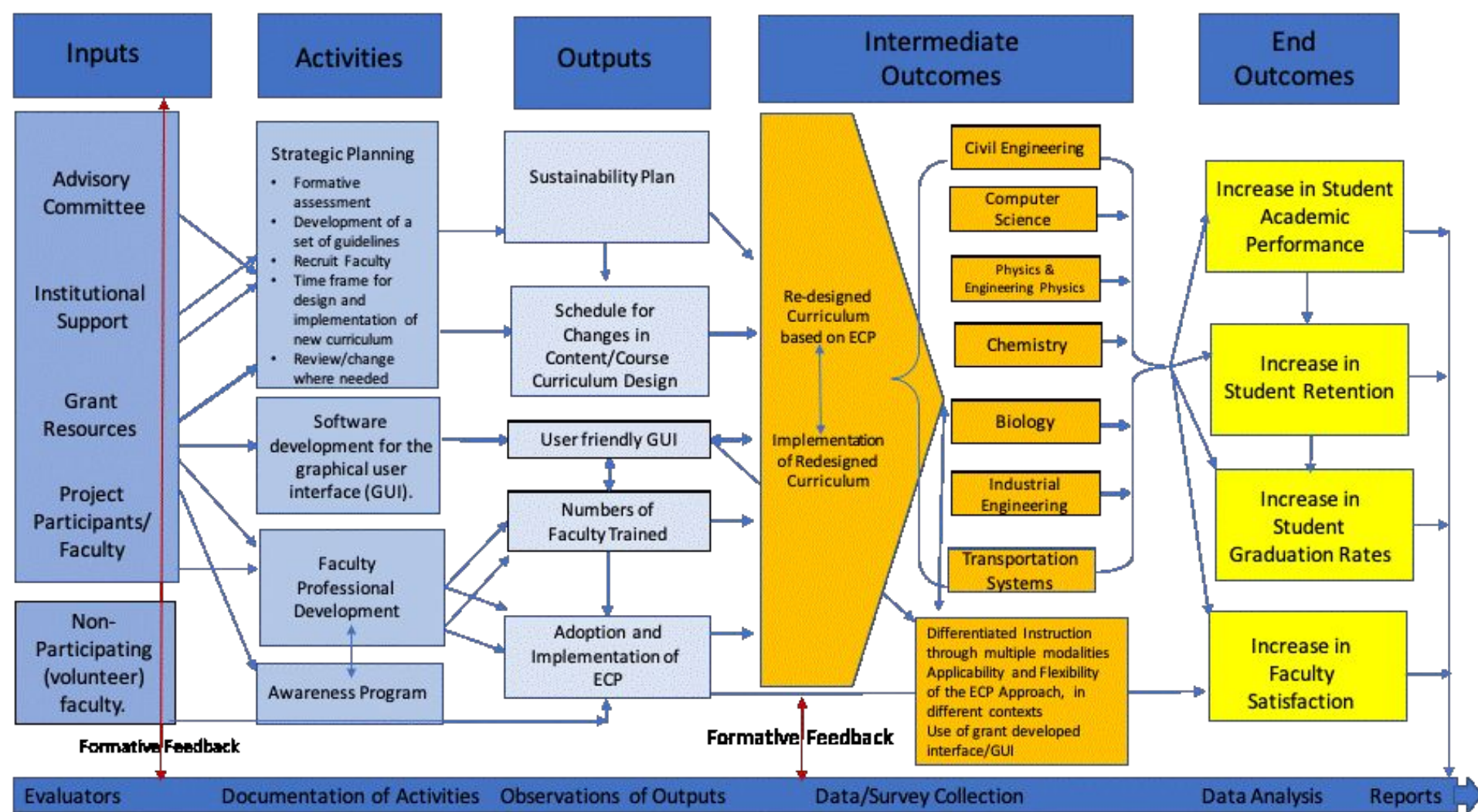

Project Details

- Project Dates: November 1 , 2019 - October 31, 2022
- Continuing grant
 - Approved on scientific / technical merit
 - Contingent on the availability of funds and the scientific progress of the project
 - Initial Award: Years 1 & 2, final year is contingent on progress



Goal /Objectives	Year 1			Year 2			Year 3			
	Fall	Spring	Summer	Fall	Spring	Summer	Fall	Spring	Summer	
1. To Train STEM Faculty										
1.1 To create awareness										
1.2 To offer professional development										
1.3 To document implementation of ECP										
1.4 To offer a ECP instructional program										
2. To diffuse ECP across STEM disciplines										
2.1 To offer STEM Instructions										
2.2 Development of multidisciplinary ECP										
3. To improve students' success rate across STEM										
3.1 To increase student learning and performance										
3.2 To increase student retention										
3.3 To increase student graduation rate										
4. Creation of Institutional Advisory Board										
4.1 To monitor the ECP										
4.2 To offer professional development										
4.3 To offer a sustainable plan for the project										

High-level Research Questions

1. Does the Experimental Centric Pedagogy (ECP) enhance student learning, motivation and curiosity beyond the field of electrical engineering?
2. How do the different STEM fields integrate and customize the Experimental Centric Pedagogy to meet the learning objectives of coursework within their disciplines?
3. Does an Experimental Centric Pedagogy increase the engagement of undergraduate students in their STEM learning and lead to measurable and lasting learning gains?
4. How does the implementation of the Experimental Centric Pedagogy impact students' learning in the various STEM fields?

Courses and Concept Where ECP will Be Implemented

Disciplines (2017 Majors - BS)	Concepts	Courses
Civil Engineering (414)	Vibration of Civil Engineering Systems, Bridge Vibrations,. Bending of Cantilever, 4. Stresses and Strains	CEGR 212 Mechanics of Materials and Laboratory, 2. CEGR 324 Structural Analysis and Laboratory
Computer Science (242)	Computer Architecture, .Digital Designing, Computer Logic and Bus	COSC243 Computer Architecture COSC 247 Digital Logic
Physics and Engineering Physics (12)	Sensor Motion, Acoustic, Heat, Kinematics, Displacements	PHYS 101 Introduction to Physics, PHYS 111 Introduction to Physics (Honors), PHYS 306 Solid State and Digital Electronics, PHYS 311 Acoustic and You, PHYS 412 Laboratory Use of Microcomputers
Chemistry	Electrolysis, Forensic, Analytic Chemistry, Optics, Spectroscopy Chemical Properties and Atomic Theory.	CHEM 110/110L General Chemistry for Engineering Students,
Biology (369)	Bio cells, Oxygen Cells, Dissolved Oxygen, Water Level, Ecology, Aquatic Habitat/Ecology	BIO 101/102/103 Introductory Biology
Industrial Engineering (153)	Manufacturing Process Monitoring, Optics, Material Properties and Testing, System Quality Control, Heat Transfer and Thermal Conductivity Measurements	IEGR 309 Material Engineering, IEGR 305 Thermodynamics IEGR 363/363 L Manufacturing Process and Lab, IEGR 367 Production and Operations management
Transportation Systems (79)	Reaction Time, Crash Analysis, Speed Measurements, Simulations of Cars, Traffic Control and Devises Traffic Counts	TRSS 414 Traffic Engineering, TRSS 415 Highway Engineering, TRSS 417 Intelligent Transportation System

Spring 2020 Pilot Courses

Biology - Introductory Biology I, BIOL 101.H02

Chemistry - CHEM 203L, CHEM 204L

Civil Engineering - CEGR 324, CEGR 212, CEGR 416

Industrial Engineering - IEGR305.001, IEGR309.001

Physics - PHYS 205L.007, PHYS 206L.002

Spring 2020 - Sample labs

Biology 101	Lab 1: Scientific method - Measuring heart rate
	Lab 6: Enzymes, digestion, respiration
	Lab 7: Photosynthesis
Civil Engineering	Strain Gage
Physics	Lab 26: Equipotential and Electric Fields
	Lab 28: Resistance and Ohms Law
	Lab 33: RC time constant
	Lab 37: LRC Circuits
	Lab 38: Oscilloscope Measurements

MSU Faculty Team

Principal Investigators: Kemi Ladeji-Osias (Lead), Md M. Rahman, Uttam Gaulee, Krishna Bista, Oludare Owolabi

Participating Faculty/Senior Personnel: Mansoureh Jeihani, Steve Efe, Mehdi Shokouhian, Anthony Kinyua, Akin Oni, Adedayo Aribiyi, Niangoran Koissi, Seong Lee, Celeste Chavis

MSU Student Team

First Name	Last Name	Lead Faculty	Assigned Department
Amrita	Bhandari	Dr. Krishna Bista	ASLP
Caroline	Ndirangu	Dr. Akin Oni	Biology
Ida	Yanou Mougang	Dr. Niangoran Koissi	Chemistry
Sotonye	Ikiriko	Dr. Oludare Owolabi	Civil Engineering
Kurt	Kennedy	Dr. Antony Kinyua	Physics
Oludayo	Alamu	Dr. Seong Lee	Industrial Engineering
Ayodeji	Wemida	Dr. Kemi Ladeji-Osias	Electrical Engineering
Mojeed	Bello	Dr. Kemi Ladeji-Osias	System Design
Emmanuel	Olanrewaju	Dr. Kemi Ladeji-Osias	Design and Programming

Student Professional Development

- November/December 2019
 - Training on ADALM2000
- Winter 2020
 - Curriculum Development/Refinement
- Share progress and train new students
 - Summer 2020
 - Summer 2021
 - Summer 2022

Student Trainee Support

- Graduate Students (8)
 - One per Department (except Physics)
 - Two project-wide - EE and education
 - Payments will be processed for the end of each month - two payments in December.
 - Tuition payments will start in Spring 2020.
 - About 20 hours per week during the school year and full time in the summer. (\$1,400/mo for 9 months, \$2,200/mo June-Aug)

Student Trainee Support

- Undergraduate Students (2)
 - Physics Department
 - No tuition
 - \$2,500/sem, \$4,000 in the summer

Student Expectations

Training: 1) Completion of the [CITI](#) Responsible Conduct of Research course, 2) Participation in ETA-STEM workshops

Development: 1) Review syllabus, 2) Develop modules, 3) Redesign curriculum, 4) Identifying sensors, 5) Provide input on Graphical User Interface (GUI) for the device, 6) Refinement of the modules.

Implementation: 1) Assist in the classroom and laboratory, 2) Assisting students with ADALM2000, Collection of completed surveys and assessments, 3) Analysis and evaluation of data.

Next steps

- Fill W-9
- Demonstration by Ayodeji Wemida